

P/N: FACCF24V-602Y4R5

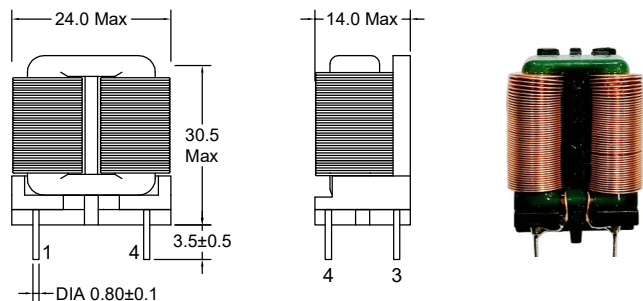

Outline Dimensions(Unit:mm)



Orthographic view

Side view

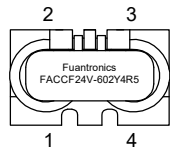

Top view

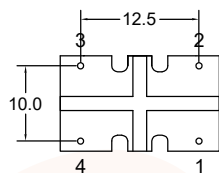

Bottom view

REMARK:

1. Product vacuum impregnation.

Electrical Characteristics(at 20°C)

Inductance : L1-2=4-3= 6.0mH Min,at 1KHz,0.1V.  
 Inductance balance : L(1-2)-(4-3)= 200uH Max,at 1KHz,0.1V.  
 Rated current: 4.50Amps.  
 Turns Ratio : Wdg1:Wdg2= 1:1±2%,at 20KHz,1V.  
 Hipot : Pri-Sec : 1500VAC/5mA/2Second.

Electronical Schematic

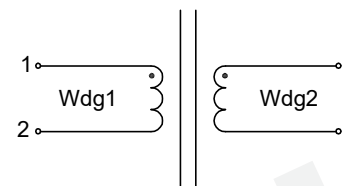

Recommended Soldering Temperature Graph.

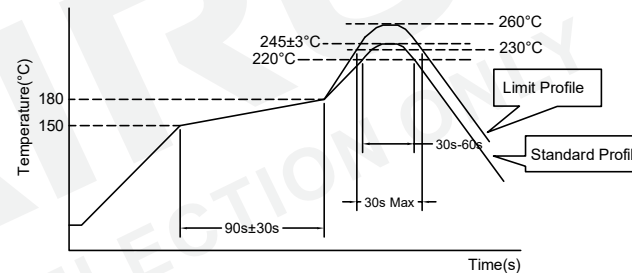

	Standard Profile	Standard Profile
Pre-heating	150~180°C,90s±30s	
Heating	above 220°C,30s-60s	above 240°C,30s Max
Peak temperature	245°C±3°C	260°C,10s
Cycle of reflow	2 times	2 times

List of UL Certificate:

Part Name	Mat'l Description	Supplier	UL Number
Bobbin	SQ24/T375HF	Chang Chun Plastics Co Ltd	E59481
Copper wire	SFT-UEW-H	Ningbo Jintian New Material Co Ltd	E227047
Core	SQ24-H10K	Su Zhou Tian Ming Magnetic	N/A
Varnish	T-4260(a)	SuZhou TaiHu Electric Advanced Material Co Ltd	E228349

\*\*\*Weight:Approx 20.8g.

				Tianchang Fuan Electronic Co Ltd www.fuantronics.net TEL: +86-550-7814888 FAX: +86-550-7831133	 Tolerances unless otherwise specified: (.X)±0.50 (XX)±0.25 Unit of measurement: mm	Make: Qiumei.Liu Checked: Beson. zhan Approved: Anson. zhan	<b>DRAWING TITLE</b> CCF24V Current-compensated frame core double chokes Material Number: A24CCF24S030	Customer P/N: Document/Rev: 00 Specification Sheet: 1 of 1 Date of Recognition: Jan./02/2020
REV	DESCRIPTION	APPD	DATE					